

DÖNER FLANŞLI LAYNERLİ EKSENEL KOMPANSATÖR

FLOATING FLANGED AXIAL EXPANSION JOINTS WITH INNER SLEEVE

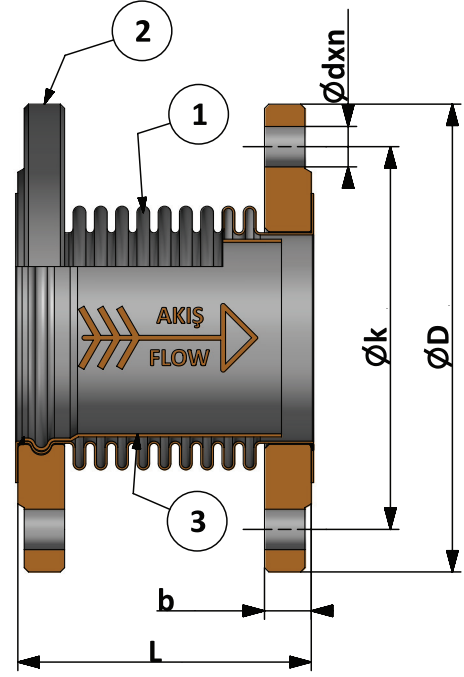

ENL-110

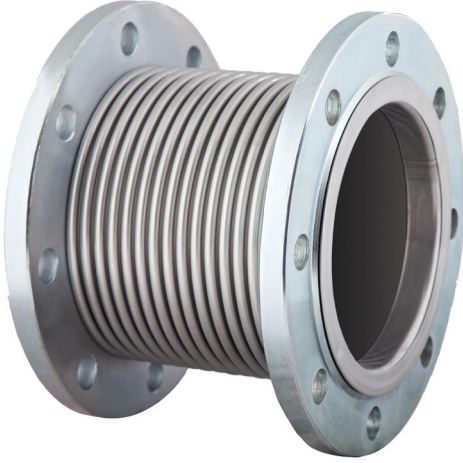

MALZEME ÖZELLİKLERİ MATERIAL SPECIFICATIONS

Parça Tanımı / Part Description	Adet / Pcs.	Malzeme / Material
1. Körük / Bellow	1	1.4301 (AISI 304) - Paslanmaz Çelik / Stainless Steel
2. Flanş / Flange	2	1.0038 (ST.37-2) - Karbon Çelik / Carbon Steel
3. Layner / Inner Sleeve	1	1.4301 (AISI 304) - Paslanmaz Çelik / Stainless Steel

GENEL ÖZELLİKLER GENERAL SPECIFICATIONS	Tasarım / Design	TS 10880, EN 14917, EJMA
Bağlantı Şekli / Connection Type	Döner Flanş - Rotary Flanged	
Körükler / Bellows	AISI 304 Paslanmaz Çelik - Stainless Steel (Opsiyonel / Optional; AISI 316L/316Ti/321)	
Bağlantı / Connection	St. 37.2 Karbon Çelik - Carbon Steel (Opsiyonel / Optional; AISI 304/316)	
Nominal Çaplar / Nominal Diameter	DN 25 (1") - DN 5000 (200")	
Çalışma Basıncı / Working Pressure	PN16 (Opsiyonel / Optional; PN25, PN40)	
Çalışma Sıcaklığı / Working Temperature	-80/+427°C (Opsiyonel / Optional; -80/+1100°C)	
Uygulamalar / Applications	Sıcak ve soğuk su sistemleri, basınçlı hava, kızgın su, buhar, kızgın buhar, kızgın yağ sistemleri. Hot and cold water systems, compressed air, superheated water, steam, superheated steam systems, superheated oil systems.	

Anma Basıncı / Nominal Pressure		PN16											
Anma Çapı / Nominal Diameter	DN	25	32	40	50	65	80	100	125	150	200	250	300
ENL-110-30	L 30mm [-20...+10mm]	110	110	120	120	120	120	120	125	130	150	165	165
ENL-110-60	L 60mm [-40...+20mm]	-	-	-	180	180	180	185	190	200	230	245	245
ENL-110-30	Eksenel Hareket / Axial Movement	30mm [-20...+10mm]											
ENL-110-60		60mm [-40...+20mm]											
Boyutlar / Dimensions (mm)	ØD	115	140	150	165	185	200	220	250	285	340	405	460
	k	85	100	110	125	145	160	180	210	240	295	355	410
	b	16	18	18	20	20	20	22	22	24	26	29	32
	dxn	14x4	18x4	18x4	18x4	18x4	18x8	18x8	18x8	22x8	22x12	26x12	26x12