

KAUÇUK KOMPANSATÖR FLANŞLI RUBBER EXPANSION JOINTS FLANGED

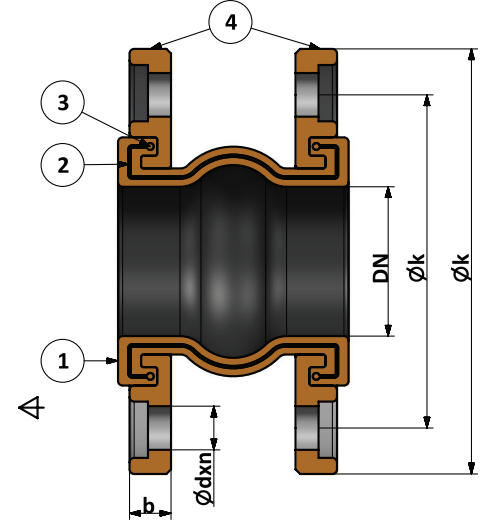

ENL-800



MALZEME ÖZELLİKLERİ MATERIAL SPECIFICATIONS

Parça Tanımı / Part Description	Adet / Pcs.	Malzeme / Material
1. KAUÇUK KÖRÜK / Rubber Bellow	1	EPDM / NBR
2. KORD BEZİ / Cord Fabric	1	Sentetik Fiber / Nylon 6.6
3. FLANŞ / Flange	2	EN-GJS 400 - Sfero Döküm + Galvaniz Kaplama / Ductile Iron + Galvanize Plated
4. SEGMAN / Steel Ring	2	1.0038 (ST.37-2) - Karbon Çelik / Carbon Steel

GENEL ÖZELLİKLER GENERAL SPECIFICATIONS

Bağlantı Şekli / Connection Type	Döner Flanş - Rotary Flanged
Körükler / Bellows	EPDM (Opsiyonel / Optional; NBR/CR)
Bağlantı / Connection	EN-GJS 400 - Sfero Döküm + Galvaniz Kaplama - Ductile Iron + Galvanize Plated (Optional; St. 37.2 Karbon Çelik - Carbon Steel/AISI 304/316)
Nominal Çaplar / Nominal Diameter	DN 25 (1 1/4") - DN 600 (24")
Çalışma Basıncı / Working Pressure	PN16
Çalışma Sıcaklığı / Working Temperature	-10 +90°C
Uygulamalar / Applications	Pompalar, Vantilatörler, Soğutucular, Hava Kompresörleri, Tersaneler, Demir Çelik Endüstrisi, Kimyasal Uygulamalar Applications, Pumps, Fans, Chillers, Air Compressors, Marine Application, Iron and Steel Factories, Chemical Applications



Anma Basıncı / Nominal Pressure	PN16																			
Anma Çapı / Nominal Diameter	DN	25	32	40	50	65	80	100	125	150	200	250	300	350*	400*	450*	500*	600*		
Boyutlar / Dimensions (mm)	L	100	100	100	100	100	100	100	120	120	120	130	130	160	240	250	270	260		
	ØD	115	150	150	165	185	200	220	250	285	340	405	460	520	565	615	670	780		
	Eksenel Genleşme / Axial Expansion	+10mm																		
	Eksenel Kapanma / Axial Compression	-20mm																		
	Yanal Hareket / Lateral Movement	15mm																		
	Açısal Hareket / Angular Movement	10°																		
		k	85	100	110	125	145	160	180	210	240	295	355	410	470	525	565	620	725	
	b	16	16	16	18	18	20	20	22	22	24	26	28	30	26	28	28	28		
	dxn	14x4	19x4	19x4	19x4	19x4	19x8	19x8	19x8	23x8	23x12	26x12	26x12	26x16	26x16	26x20	26x20	30x20		
Ağırlık / Weight	Kg	1,8	3,3	3,8	4,5	5,2	6,7	7,8	9,6	11,8	16,8	20	28	42,4	46	51	57	70		

* Çelik Flanş / Steel Flange

